

General Rubber Lining Principles

I. Metal Prerequisites

Metal to be lined should meet the requirements as stated in section 8 “Metal Fabrication” and section 12 “Blasting and Cementing Procedures.” The surface of the metal needs to be free of pits and crevices. Pits and crevices will trap air which will expand during the cure, causing the lining to form a blister known as a “blow”. The primer and any intermediate can be applied ahead of time. The tack cement should be applied ahead of the application of the lining sheets so that, 1) the cement is dry and tacky, and 2) the cement is applied just far enough so that the last sheet of rubber is applied at the end of the shift. In this way, the tack cement won’t become so dry that the rubber won’t stick when ready.

The temperature of the equipment to be lined must be higher than 60° F (15°C). Any colder and the rubber applicators will have difficulty applying the rubber and the adhesives may not dry in a timely manner. The rubber linings are easier to apply when they are warmed to 120° F (48°C) on a warming table just prior to use.

II Primer and Cement Application

The primer and any intermediate can be applied ahead of the lining application – see the appropriate data sheets for maximum tack or lay-over times. The tack cement should be applied the same day as the sheet application. Be certain the cement is solvent free but still tacky. Any areas that have been cemented but not lined in one day should be re-cemented the next day to insure good adhesion.

III. Lining Guidelines

Sheets of rubber should be unrolled and then cut to the desired size and shape on a clean table. Some linings require heated tables for easier lining or to preshrink the rubber. Care needs to be taken so that the tie gum side of the lining, if present, is facing out for cementing. The edges should be cut with a minimum skive of 45° to aid in forming the seam. For best results the plastic side of the lining, once removed, should be cemented and applied to the substrate. When the lining requires preshrinking it should be unrolled on the table, remove the plastic and allowed to shrink prior to cutting it to size. After the cement is applied and allowed to dry, a liner should be put on the rubber sheet and then be positioned on the cemented metal and partially tacked down as the liner is pulled out. The lining can be rolled down using steady, firm and overlapping strokes with roller of 2 1/2" maximum width. When rolling, always start in the center of the panel and work toward the edges forcing all the air out from behind the lining. The craftsman can mark the portion of the panel that has been rolled to assure complete contact between rubber and metal. Air blisters found should be punctured, vented and overlaid with a 2" patch.

There are 2 styles of seams: skive butt joint, with or without cap strips, and overlap (open or closed skive). The Lining Specification should be referred to in order to ensure the proper seam style is used. The skive butt joint with cap strips is shown below with the cap strips having an open skive. The overlap method is also shown with a closed skive. Open skives are used when the rubber is a one construction lining. A closed skive is used on a multiple construction lining to protect the underlying plies, such as a Tri-bond™ or tie gum (tack back) lining construction.

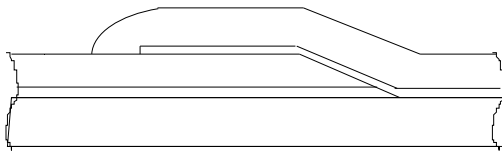

Closed Skive Overlap

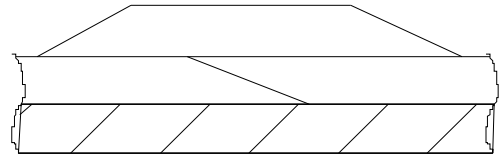

Butt Joint with cap strip

The most common seam construction uses a 2" overlap with a closed skive. The panels are skived with a minimum 45° up skive on the bottom, and the top has a 45° down skive on the exposed edge. In corners where triple lining thickness appear, you can cut out a piece of lining on the second layer of stock approximately 2" square. In abrasion service or high flow areas, care should be taken to ensure that seams are in the direction of flow to prevent lifting of the seams.

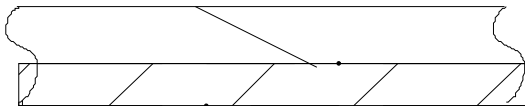

Butt Seam

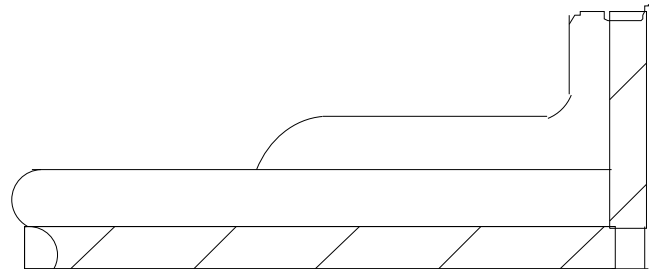

Corner Seam Closed Skive

Where skive butt joints are required the sheets of lining are skived at a minimum 45° angle and mated together. If a cap strip is required, it should be at least 3" wide with the seam in the middle.

Care should be taken to ensure the lining is not stretched or applied in tension. Care needs to be taken in corners where the lining can be folded in, or joined and seamed. A "V" strip fillet can be used on sharp inside corners to give them sufficient radius.

The sheets of lining should be applied so that there is a minimum amount of wasted stock. The panels can be laid vertically or horizontally on the sides and cross-wise in the bottom. In cylindrical tanks it is typically easier to apply vertical panels. The seams should always be staggered to avoid four (4) layers of rubber. Neatness and uniformity will ensure the job looks professional.

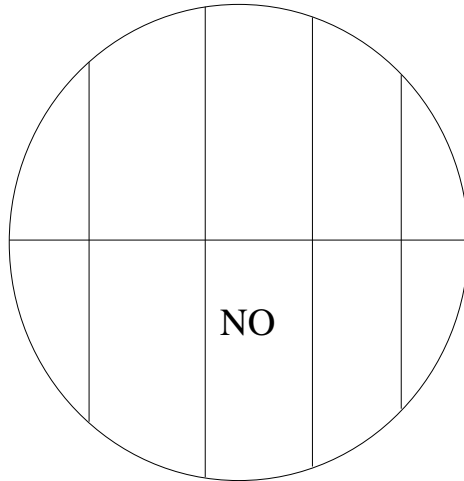

Seams Aligned

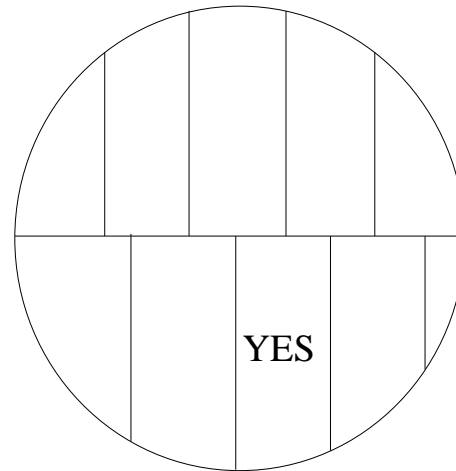

Seams Offset

When lining tanks outside the shop, the tanks must be warmed to 60 degrees. In cold weather the tank should be covered and heating equipment brought in. **Insulation is strongly recommended.**

Tanks should be treated as a Confined Space and will require that special safety procedures be followed.

RUBBER LINING PIPE

I. Metal Specification

Pipe should be fabricated in accordance with the requirements stated in RMA Bulletin 2 (Section 8), "Specifications for Pipe and Fittings for Protective Lining." Any other requirements specified by the engineering company, or end user, shall be agreed upon by all parties prior to pipe fabrication.

II. Metal Preparation

All surfaces to be lined shall be blasted to a white metal blast per SSPC-SP5 or NACE #1. The surface should be free from all oil, grease, dirt, mill scale, rust or other foreign matter. See Section 12 - Blasting and Cementing Procedures.

III. Cementing

Apply primer immediately after blasting. Apply additional coats of primers and cements as specified by BLAIR Rubber Company. Primers and cements are normally applied on the inside of pipe with a swab, spray or roller. Allow sufficient drying time between cement coats. More information is available in Sections 5 and 12.

IV. Lining Procedure for Standard Flanged Pipe

- A. Form a tube with lining stock using longitudinal skived seams. This can be accomplished by wrapping the lining stock around a mandrel, using a liner inside the tube, or any other method to facilitate the making of a tube. The spliced tube's outside circumference should be slightly less than the inside circumference of the pipe and the tube length should be longer than the pipe's length.
- B. Apply twisted multifilament cotton string lengthwise to permit proper air venting between the pipe and lining. Do not use string made from synthetic yarns. Stringing should be done after cementing and the individual strings should be spaced equally around the circumference. Normally, four strings are used on pipe with diameters up to and including six inches. Larger size pipe normally uses additional strings. String is optional for some methods of lining.
- C. Enclose the tube in a liner and attach a towrope. Pull tube into pipe with a slow constant pull.
- D. Remove liner and expand tube against pipe wall by using air pressure. A mechanical extension and flange arrangement may be used for the pipe ends so a minimum of 10psi internal pressure can be maintained in the expanded tube for at least five minutes.
- E. Remove extension and flare excess stock over flange face and trim flush with the flange face.
- F. Apply a covering to the full face of the flange. Skive ID of flange stock to slightly less than ID of lining and stitch firmly to tube stock. When using hard rubber lining on flanges, it is important that customer understand that soft rubber gaskets are required on the flanges.

- G. On pipe sizes larger than 6", the flange face stock may be lapped onto the lining inside the pipe instead of the skive used on smaller sizes. This lapping technique makes a stronger joint and is the preferred method. Some customers may prefer not to have laps inside the pipe at flanges because of abrasion considerations or requirements on full line capacity. (See various flange covering sketches for alternate procedures, Sketches 301 and 302).
- F. See Sketch 304 and 305 for suggested lining styles of lateral nozzles and side outlets.

V. Lining Procedure for Victaulic Pipe

- A. Line inside of pipe in accordance with procedures used for standard flanged pipe.
- B. When using 1/8" through 1/4" linings, the tube lining should be extended over the end of the pipe and bent back into the recess on the outside of the pipe. Apply a round of friction tape over the OD of outside rubber. After cure, remove tape and buff OD flush with OD of metal (see Sketch 303).

VI. Guidelines for Number of Laps in Pipe and Fittings

Pipe Size	No. of Max. Longitudinal Seams	No. of Circumferential Seams
3" - 6"	1	1 in 14' to 10' sections
8" - 16"	2 (180° apart)	2 in 20' sections 0 in 8' and under sections
Pipe Size	* Straight Length	
2" - 3"	14'	
4" - 8"	24'	
8" - 42"	40'	

* For maximum lengths check with your Applicator.

Flange Lining Methods

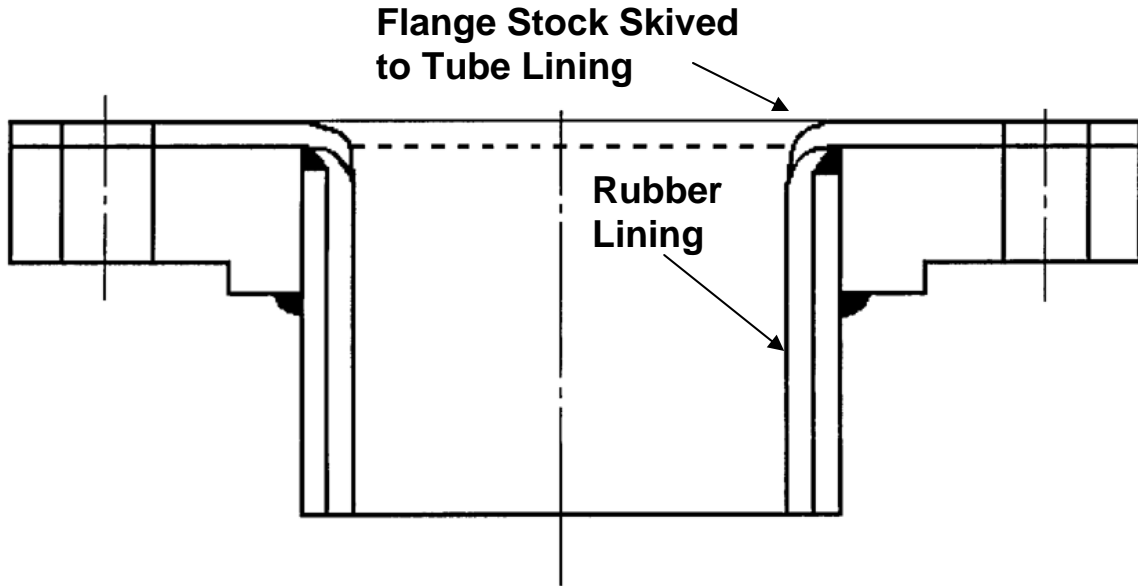

Sketch 301

Flange Lining Methods

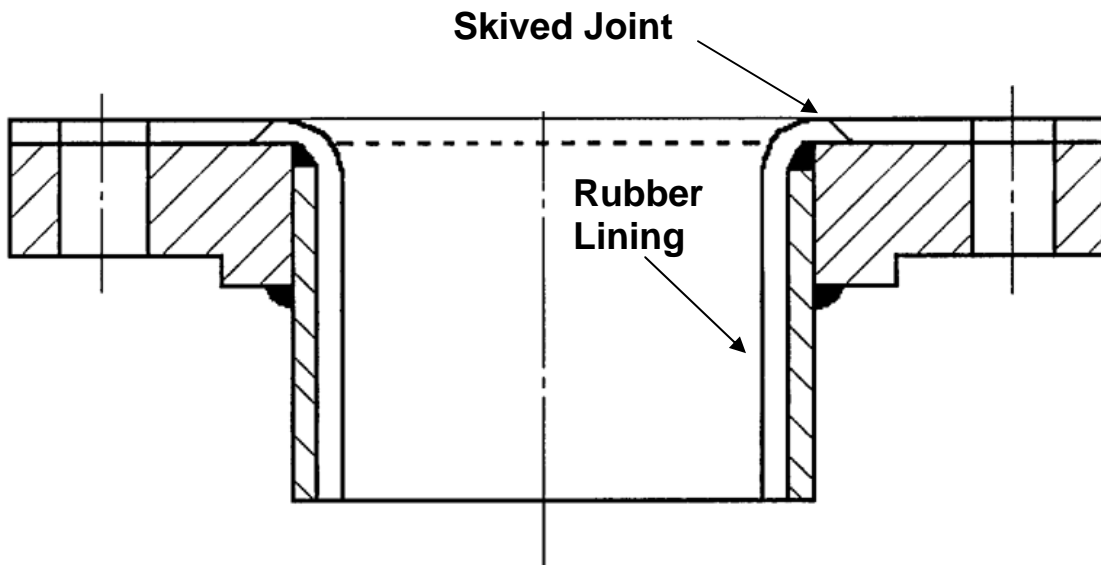

Sketch 302

Rubber Lining for Double Grooved Victaulic Pipe

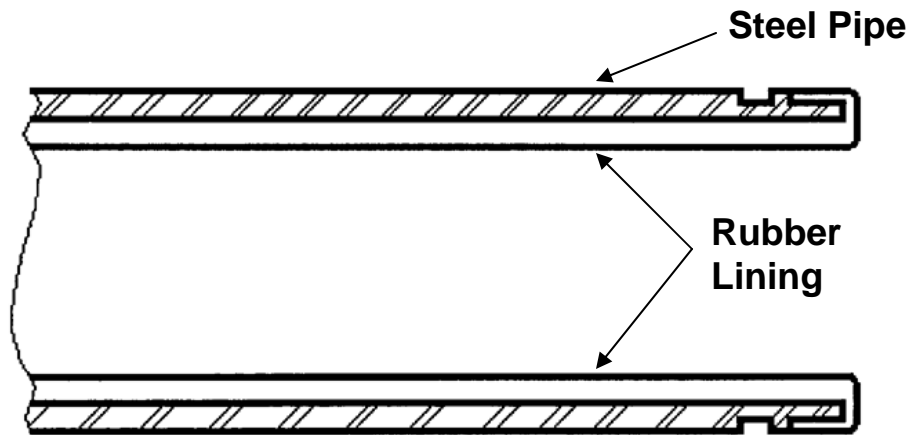

Sketch 303

90° Nozzle Lining

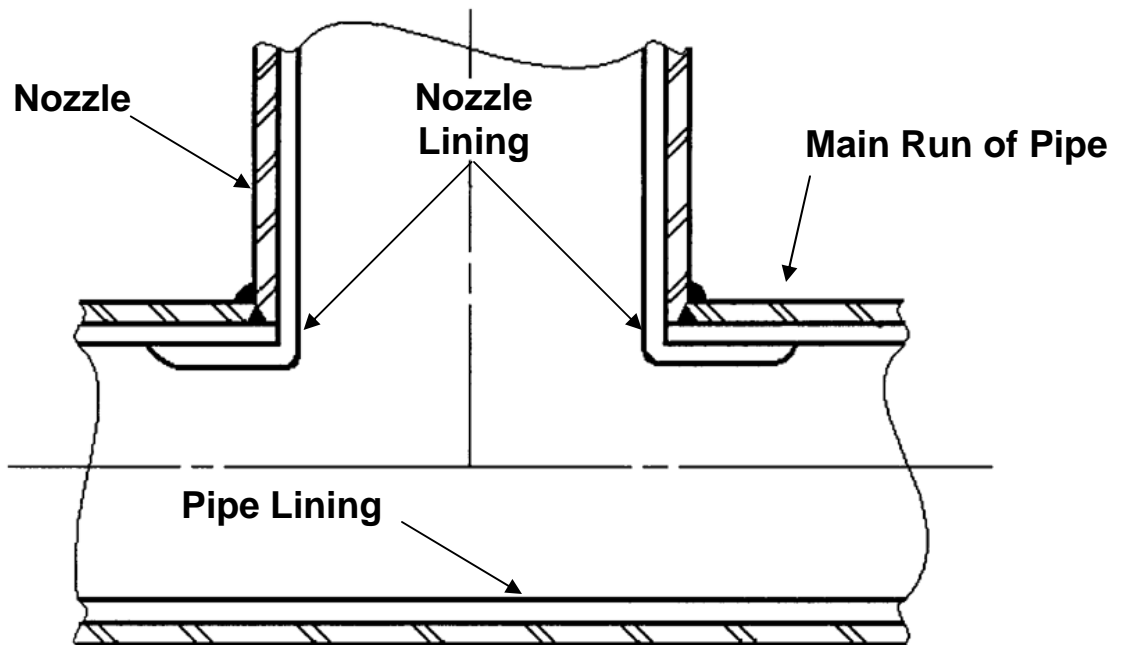

Sketch 304

Lateral Nozzle Details

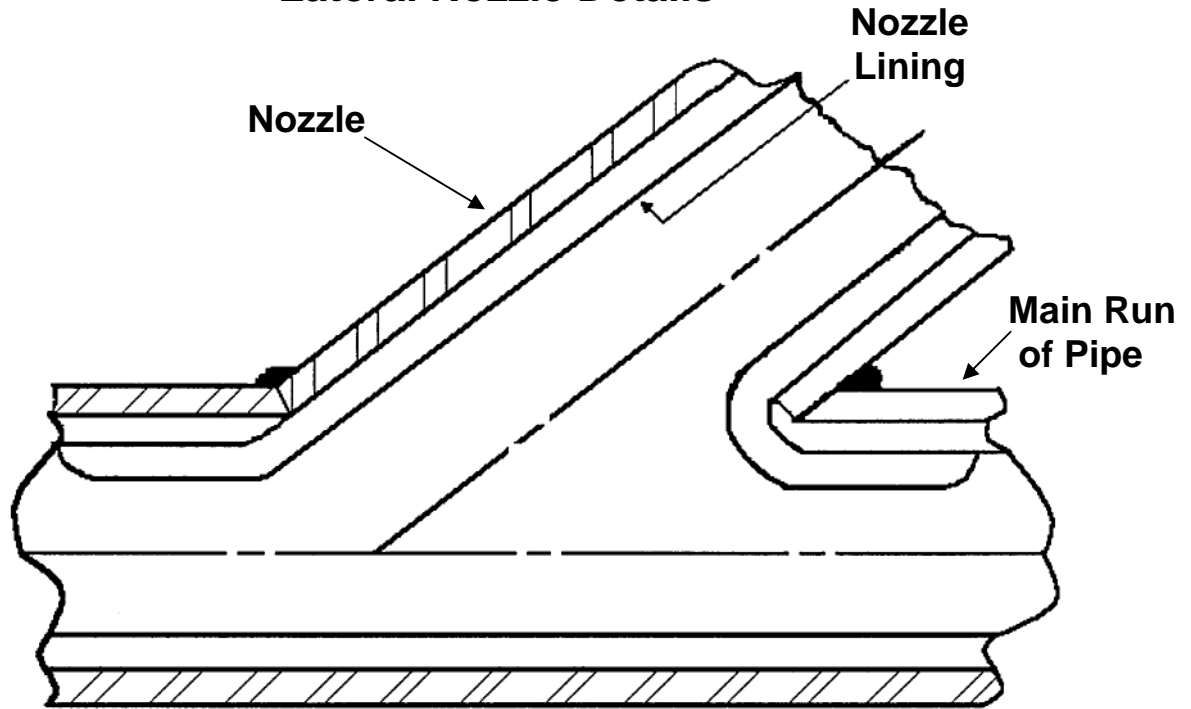

Sketch 305

Sketch F-1
**Flange Construction
Using Precured Rubber**

